

**ELECTRONIC BALLAST WITH PFC
USING L6574 AND L6561**

by I. Dal Santo, U. Moriconi

The advent of dedicate IC for lamp ballast applications is replacing the old solutions based on bipolar transistor driven by a saturable pulse transformer.

The L6574 is an innovative high performance ballast driver, designed in 600V BCD OFF-LINE technology, which ensures all the features needed to drive and control properly a fluorescent bulb. It is provided with a built-in VCO and an OP-AMP, useful to implement a closed loop control of the lamp current, therefore of the lamp power.

INTRODUCTION**Half bridge converter for electronic lamp ballast**

Voltage fed series resonant half bridge inverters are currently used for fluorescent lamps (fig.1). This topology allows to easily operate in Zero Voltage Switching (ZVS) resonant mode, reducing the transistor switching losses and the electromagnetic interference. Moreover, by varying the switching frequency it is possible to modulate the current in the lamp, therefore the output power.

To design a cost effective, compact and smart electronic lamp ballast it could be used a dedicated IC able to drive directly the power MOSFETs of the half bridge. Such controllers require a high voltage capability for the high side floating transistor driver.

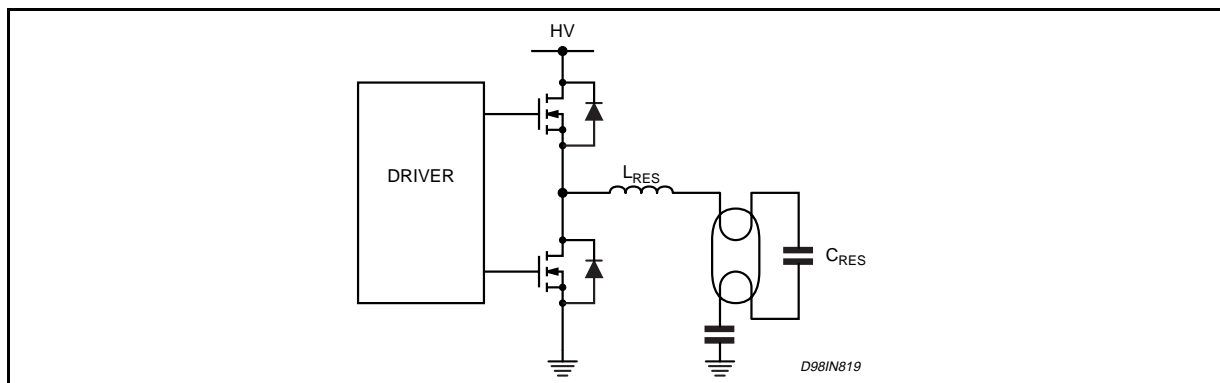
Figure 1. Half Bridge topology**Lamp requirements**

To provide long life and to insure an efficient ignition of the lamp the cathodes must be preheated. In fact the preheating of the filaments allows an easy strike of the lamp reducing ignition voltage. During preheating time the lamp is characterised by a high impedance and the current flows only in the filaments. The resistance value of the filaments are strictly dependent on the lamp model. Typically these filaments present a initial low value (a few Ohms) that will increase by 5 times during the preheating.

After the preheating time the lamp must be ignited, by increasing the voltage across it. The ignition voltage value also depends on the lamp type, and it increases with the ageing. For a typical TL 58W it is not much less than 1000V. Using a simple inverter, with a constant switching frequency, external circuitry must be used (e.g. PTC or discrete timer). Instead with the ST L6574 smart controller both the preheating and the ignition functions are achieved by using simple resistors and a capacitor, which set all the start-up procedure.

L6574 Ballast Driver

The L6574, whose internal block diagram is shown in fig.2, is an IC intended to drive two power MOS or IGBT, in half bridge topology, ensuring all the features needed to drive and control properly a fluorescent bulb. The device is available in DIP16 and SO16N packages.

The most significant features of the L6574 concern the following points:

- high voltage rail up to 600V;
- dV/dt immunity ± 50 V/ns in full temperature range;
- driver current capability (250 mA source and 450 mA sink);
- switching times 80/40 ns rise fall with 1 nF load;
- CMOS shut down input;
- under voltage lock out;
- preheat and frequency shifting timing;
- sense OP AMP for closed loop control or protection features;
- high accuracy current controlled oscillator;
- integrated bootstrap diode;
- clamping on V_s ;
- SO16, DIP16 package.

Figure 2. Internal Block diagram of the L6574

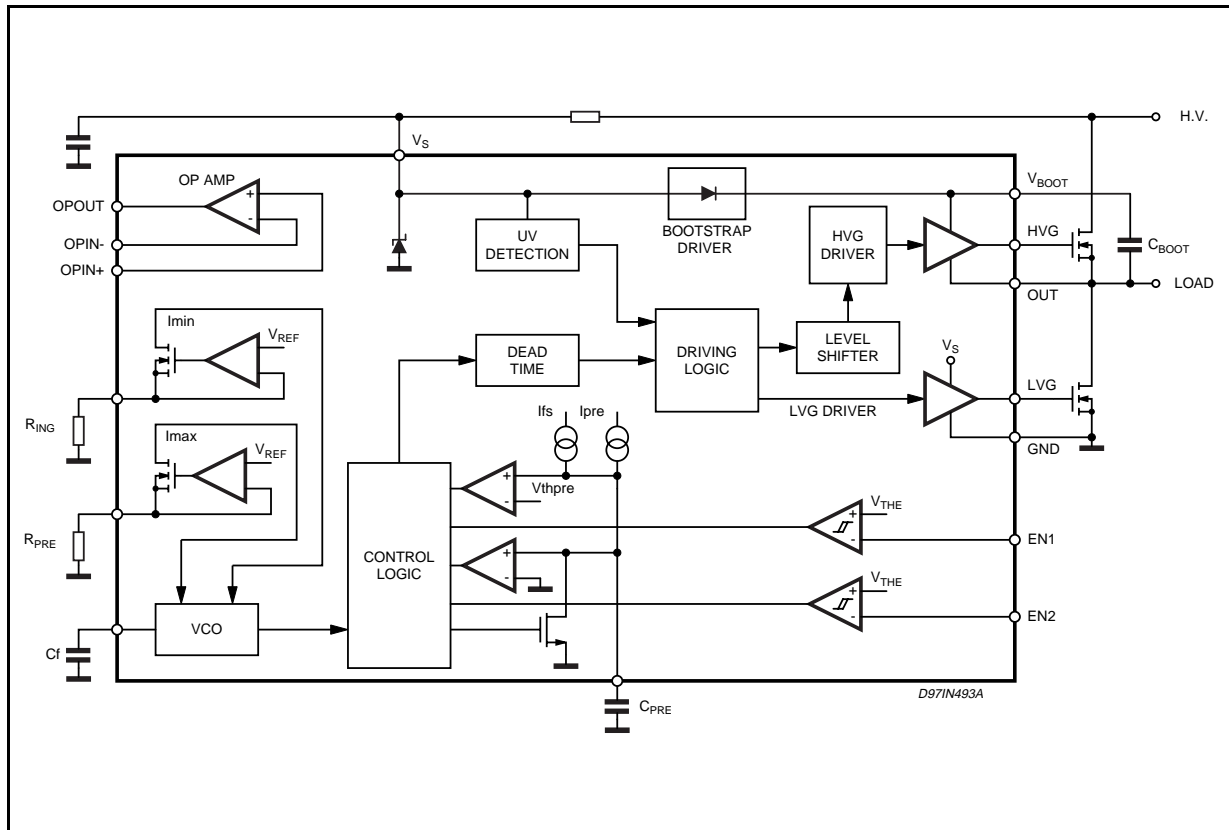

Device Pins Description

| N. | Name | Function |
|----|-------------------|-----------------------------------------------------------------------------------------------------------------------------------------------------------------------------------------------------------------------------------------------------------------------------------------------------------------------------------------------------------------------------------------------------------------------------------------------------------------------------------------------------------------------------------------------------------------------------------------------------------------------------------------------------------------------------------------------------------------------------|
| 1 | C _{PRE} | Preheat Timing Capacitor. The capacitor C _{PRE} sets the preheating and the frequency shift time, according to the relations: $t_{PRE} = 1.5C_{PRE}$, $t_{SH} = 0.15C_{PRE}$ (typ). This feature is obtained by charging C _{PRE} with two different currents. During t _{PRE} this current is independent of the external components, so C _{PRE} is charged up to 3.5 V (preheat timing comparator threshold). During t _{SH} the current depends on R _{PRE} value (i.e. on the difference between f _{PRE} and f _{ING}). In this way t _{SH} is always set at 0.1t _{PRE} . In steady state the voltage at pin 1 is 5V (see fig.5). |
| 2 | R _{PRE} | Maximum Oscillation Frequency Setting. The resistance connected between this pin and ground sets the f _{PRE} value, fixing the difference between f _{PRE} and f _{ING} (f _{PRE} > f _{ING}). The voltage at this pin is fixed at V _{REF} = 2V. |
| 3 | C _F | Oscillator Frequency Setting. The capacitor C _F , along with to R _{PRE} and R _{ING} , sets f _{PRE} and f _{ING} . In normal operation this pin shows a triangular wave. |
| 4 | R _{ING} | Minimum Oscillation Frequency Setting. The resistance connected between this pin and ground sets the f _{ING} value. The voltage at this pin is fixed at V _{REF} = 2V. |
| 5 | OP _{out} | Out of the operational amplifier. To implement a feedback control loop this pin can be connected to the R _{ING} pin by means an appropriate circuitry. |
| 6 | OP _{in-} | Inverting Input of the operational amplifier. |
| 7 | OP _{in+} | Non Inverting Input of the operational amplifier. |
| 8 | EN1 | Enable 1. This pin (active high), forces the device in a latched shutdown state (like in the under voltage conditions). There are two ways to resume normal operation. The first is to reduce the supply voltage below the undervoltage threshold and then increase it again until the valid supply is recognised. The second is activating EN2 input. The enable 1 is especially designed for strong fault (e.g. in case of lamp disconnection). |
| 9 | EN2 | Enable 2. EN2 input (active high) restarts the start-up procedure (preheating and ignition sequence). This features is useful if the lamp does not turn-on after the first ignition sequence. |
| 10 | GND | Ground. |
| 11 | LVG | Low Side Driver Output. This pin must be connected to the low side power MOSFET gate of the half bridge. A resistor connected between this pin and the power MOS gate can be used to reduce the peak current. |
| 12 | V _S | Supply Voltage. This pin, connected to the supply filter capacitor, is internally clamped (15.6V typical). |
| 13 | N.C. | Non Connected. |
| 14 | OUT | High Side Driver Floating Reference. This pin must be connected close to the source of the high side power MOS or IGBT. |
| 15 | HVG | High Side Driver Output. This pin must be connected to the high side power MOSFET gate of the half bridge. A resistor connected between this pin and the power MOS gate can be used to reduce the peak current. |
| 16 | V _{BOOT} | Bootstrapped Supply Voltage. Between this pin and V _S must be connected the bootstrap capacitor. A patented integrated circuitry replaces the external bootstrap diode, by means of a high voltage DMOS, synchronously driven with the low side power MOSFET. |

Application description

The design has been developed to drive a TL fluorescent lamp up to 58W. It is composed of two sections: the PFC, using the L6561 controller, and the ballast, based on the L6574 (see fig.3 and fig.4). The application is provided with a current feedback, that allows power control (and in case the dimming function) by varying the switching frequency during the normal lamp burning. The application is also provided with a safety circuitry, that acts in case of open load or faulty ignition of the lamp.

Figure 3. Application circuit

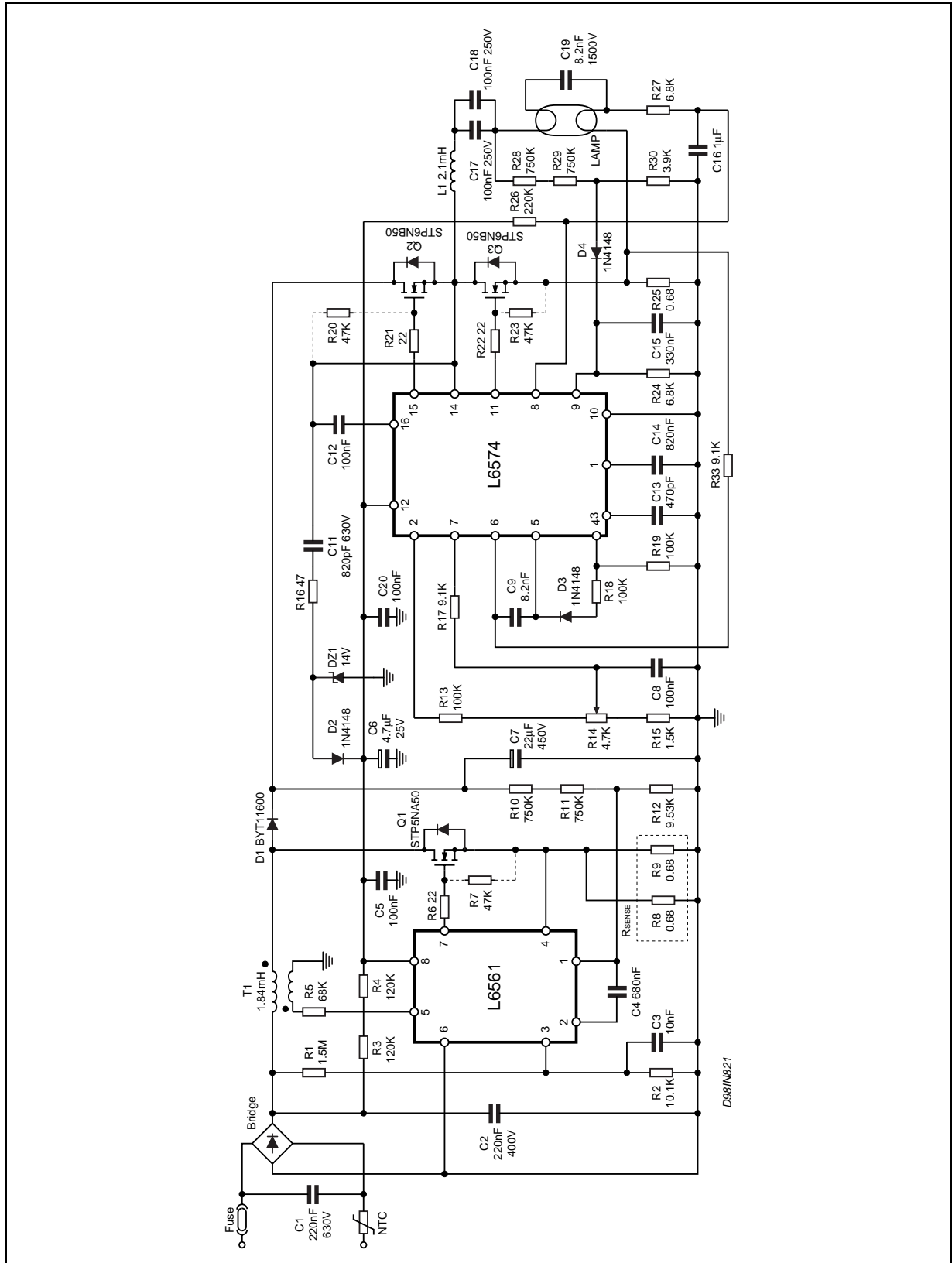
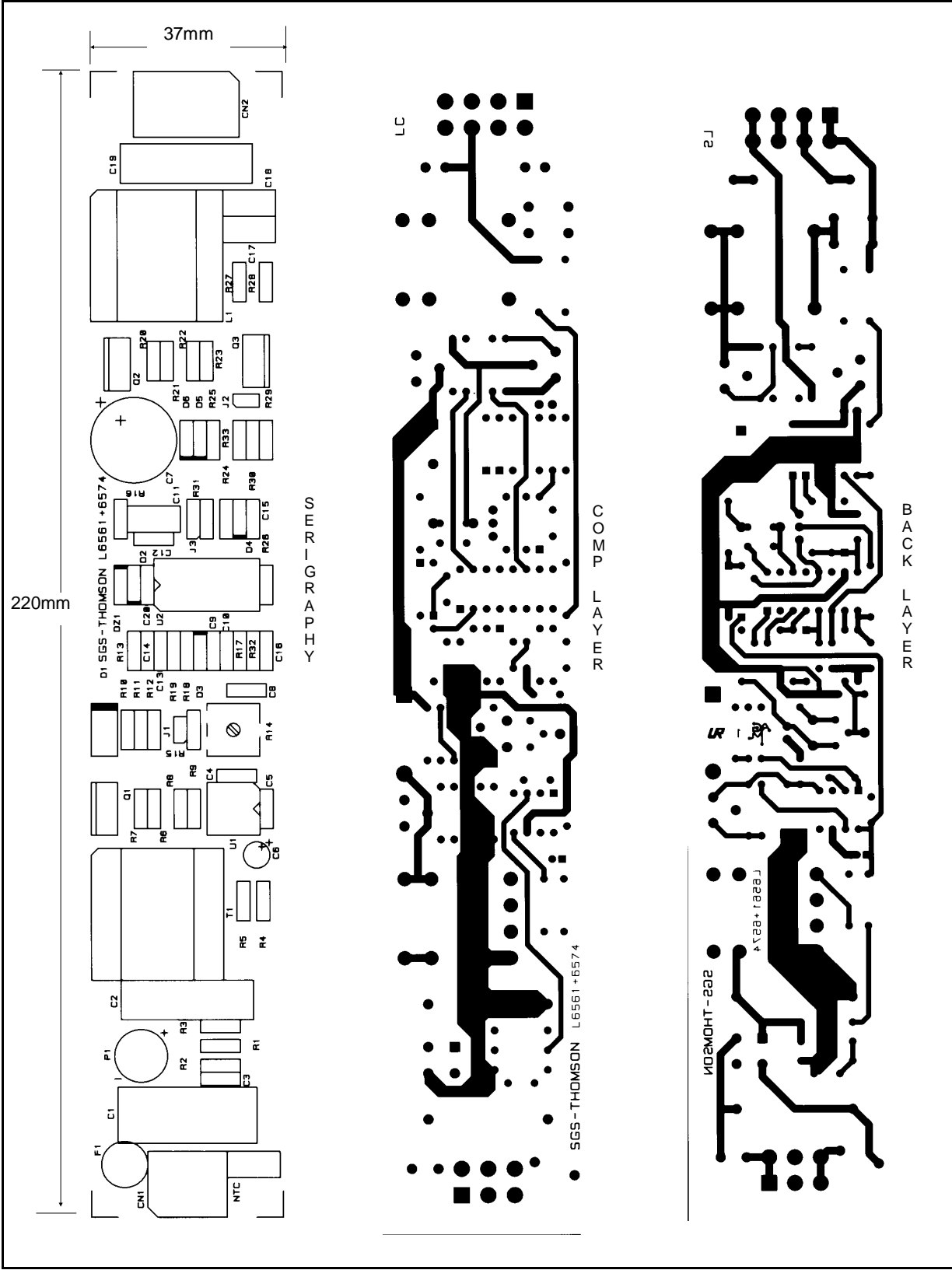

Figure 4. PCB and components layout.



Power factor section

Even if the PFC stage is not strictly necessary for electronic ballast application, in this design it has been introduced for the following reasons.

The front-end stage of conventional off-line converters, typically made up of a full wave rectifier bridge with a capacitor filter, gets an unregulated DC bus from the AC mains. Therefore the instantaneous line voltage is below the voltage on the capacitor most of the time, thus the rectifiers conduct only for a small portion of each line half-cycle. The current drawn from the mains is then a series of narrow pulses whose amplitude is 5-10 times higher than the resulting DC value.

Lots of drawbacks result from that: much higher peak and RMS current drawn from the line, distortion of the AC line voltage, overcurrents in the neutral line of the three-phase systems and, after all, a poor utilisation of the power system's energy capability.

This can be measured in terms of either Total Harmonic Distortion (THD), as norms provides for, or Power Factor (PF), intended as the ratio between the real power (the one transferred to the output) and the apparent power (RMS line voltage times RMS line current) drawn from the mains, which is more immediate. A traditional input stage with capacitive filter has a low PF (0.5-0.7) and a high THD (> 100%).

The new European norms and the International standard requirements have spurred the design of high power factor ballasts and they are starting to impose a limit on the input current harmonic content. For these reasons power factor corrector (PFC) is now diffusing in consumer and industrial lighting. With a high power factor switching preregulator, interposed between the input rectifier bridge and the bulk filter capacitor, the power factor will be improved (up to 0.99). The current capability is increased, the bulk capacitor peak current and the harmonic disturbances are reduced.

The L6561 is an IC intended to control PFC preregulators by using the transition mode technique and is optimised for lamp ballast applications.

The operation can be summarised in the following description (for more information, see AN966). The AC mains voltage, that can range from 85V to 265V, is rectified by a diodes bridge and delivered to the boost converter. The input capacitor has been split in two parts (C_1 and C_2) to increase the performance in terms of harmonic distortion (THD). In fact, due to the wide range supply and the possibility to change the output power, the minimisation of the capacitor connected after the bridge, allows to reduce the THD. The boost converter consists of a boost inductor (T_1), a controlled power switch (Q_1), a catch diode (D_1), an output capacitor (C_7) and, obviously, a control circuitry (see fig.3).

The PFC section has been designed to supply a 400V DC and a power of 60W.

Ballast Section

The regulated voltage is delivered to the ballast section. The ballast is based on the high performances L6574, which is an OFF-LINE half bridge driver designed in 600V BCD technology. It adds to the full integrated half bridge driver topology a built-in voltage controlled oscillator (VCO), a preheating start-up procedure and an operational amplifier dedicated to the feedback loop. To avoid cross conduction of the power MOSFETs or IGBTs, the internal logic ensures a minimum dead time.

The load consists of a series resonant circuit (L_1 - C_{19}) with the lamp connected across the capacitor (C_{19}). This topology allows to operate in Zero Voltage Switching, to reduce the transistor switching losses and the electromagnetic interference generated by the output wiring of the lamp.

The blocking capacitor (C_{17} // C_{18}) allows to obtain a zero average lamp current. In steady state the voltage across these capacitors is as high as half the high voltage bus, that is about 200V.

Preheating and ignition sequence

The turn-on sequence can be divided in three phases: preheating, ignition and normal lamp burning. The preheating of the lamp filaments is achieved by a high switching frequency f_{PRE} , about 60 kHz, set by $R_{PRE} = R_{13} + R_{14} + R_{15}$ and $C_F = C_{13}$, to ensure that a current flows in the filaments without lamp ignition. In fact the initial voltage applied across the lamp is below the strike potential. The duration of the preheating period t_{PRE} is set by the capacitor $C_{PRE} = C_{14}$. The choice of this time is strictly dependent on the lamp type. In the application t_{PRE} has been set at 1.2 sec.

The ignition sequence begins after t_{PRE} . The switching frequency decreases towards the resonance point (L_1 - C_{19}), increasing the voltage across the lamp, and causing the ignition. The time interval in which the frequency shifts, t_{SH} , amounts to $t_{SH} = t_{PRE}/10 = 120ms$. At the end of t_{SH} the frequency reaches 31 kHz (R_{19} - C_{13}), and then the current feedback loop is activated.

Current feedback loop

The current control is achieved by varying the switching frequency of the VCO. Since controlling the average current in the lamp means controlling the output power, it is quite easy to perform dimming function. The OP-AMP compares the low-pass filtered half-bridge current, shunted by R₂₅, with a reference, achieved by a partition of the voltage at pin 2 (V_{PIN2} = 2 V). This set-point could be changed by the trimmer R₁₄, to perform the dimming function. The OP-AMP output is connected to R_{ING} pin by D₃ and R₁₈. The diode D₃ is necessary to avoid that the switching frequency decreases below the value set by R₁₉.

At start-up the voltage across R₂₅ (fig.5) remains low until the lamp ignition. So the inverting input of OP-AMP (pin 6) stays low too, while the non inverting input (pin 7) is set at a constant voltage (set-point) by the divider R₁₃, R₁₄ and R₁₅.

Therefore the OP-AMP output (pin 5) remains high (5 V) until the lamp ignition, and D₃ is off. In this condition the L6574 oscillates at f_{PRE}.

As the lamp strikes on (after t_{PRE} and t_{SH}), the average voltage across R₂₅ increases and the feedback is able to regulate the lamp current.

Figure 5. Current feedback loop

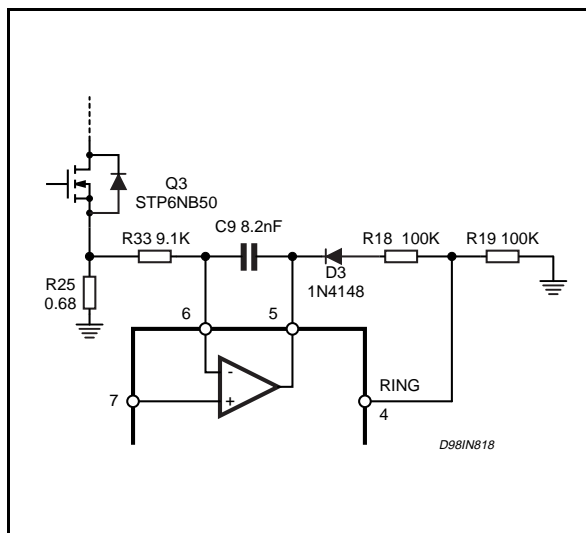
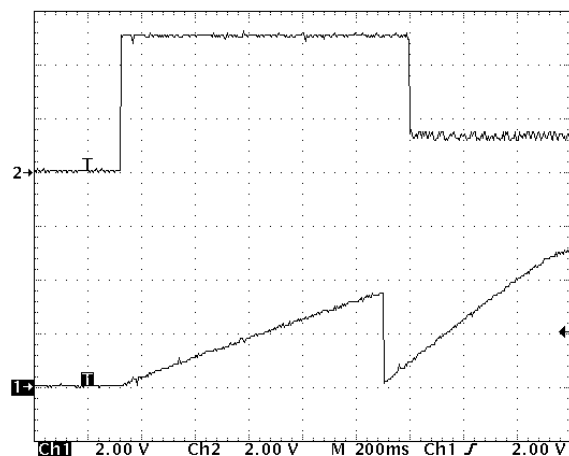

Figure 6. Cpre waveform (Ch1) and OP AMP output (Ch2)



Start-up and supply

The start-up procedure is very important in an application that contains two different sections.

The ballast section starts before the PFC, avoiding any extra-voltage at the PFC section output, and so the L6561 dynamic OVP activation (see AN966). This behaviour is guaranteed under all conditions because the V_S turn-on threshold of L6574 is lower than the L6561 one.

At start-up the L6574 is powered by the resistor (R₃ + R₄). This resistor must be chosen so as to ensure the "before start-up current" of both the L6561 and L6574.

When the ballast section is running, the charge pump (C₁₁, R₁₆, D₂ and D_{Z1}) allows to supply both the devices. The resistor R₁₆ allows to reduce the peak current.

Safety circuitry

In normal operation the inductive load ensures a zero voltage switching mode, but if the lamp is disconnected the switching losses in the power MOSFETs will increase considerably. To prevent this occurrence a safety circuitry has been designed. When the lamp is connected the EN1 input (pin 8) of the L6574 is held close to ground by the series of R₂₇, the lamp filament and R₂₅. If the lamp is not present EN1 is pulled up to V_S by R₂₆, forcing the L6574 in a latched shutdown state. To resume normal operation it is necessary to turn off the ballast and then turn it on again.

A second alarm has been designed to protect the application against the extra voltages which would arise if the lamp did not strike after the ignition sequence, because of an old lamp. A partition of this ex-

AN993 APPLICATION NOTE

tra voltage is rectified and delivered to the EN2 input (pin 9) of the L6574, restarting the start-up procedure (preheat and ignition sequence).

Figure 7. Open load safety circuit

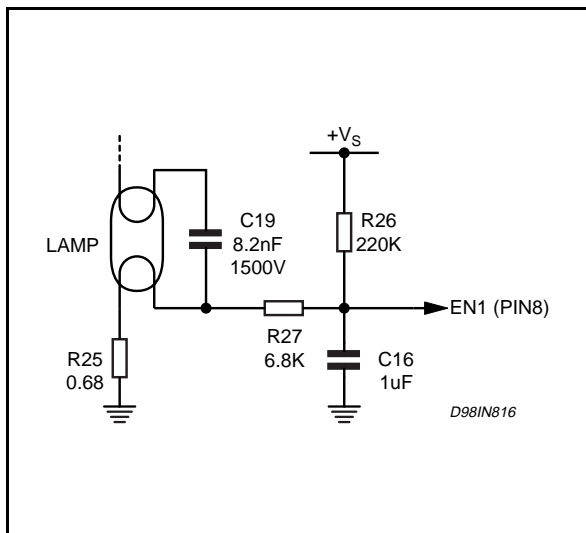
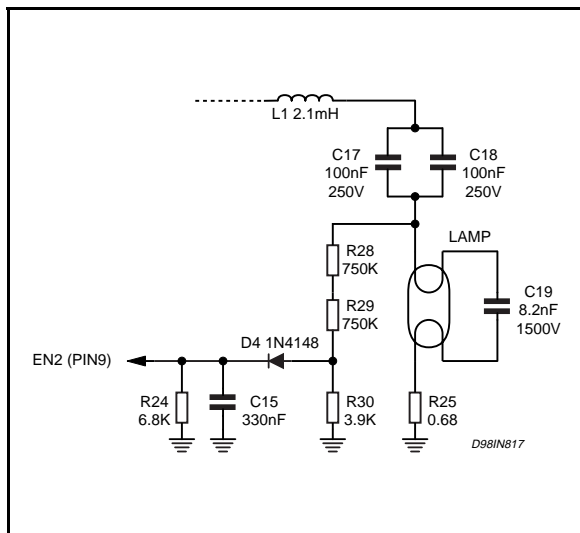

Figure 8. Extra voltage safety circuit



Information furnished is believed to be accurate and reliable. However, SGS-THOMSON Microelectronics assumes no responsibility for the consequences of use of such information nor for any infringement of patents or other rights of third parties which may result from its use. No license is granted by implication or otherwise under any patent or patent rights of SGS-THOMSON Microelectronics. Specification mentioned in this publication are subject to change without notice. This publication supersedes and replaces all information previously supplied. SGS-THOMSON Microelectronics products are not authorized for use as critical components in life support devices or systems without express written approval of SGS-THOMSON Microelectronics.

© 1998 SGS-THOMSON Microelectronics – Printed in Italy – All Rights Reserved

SGS-THOMSON Microelectronics GROUP OF COMPANIES

Australia - Brazil - Canada - China - France - Germany - Italy - Japan - Korea - Malaysia - Malta - Morocco - The Netherlands - Singapore - Spain - Sweden - Switzerland - Taiwan - Thailand - United Kingdom - U.S.A.